

# Mix<sup>PRO</sup>

# Mix<sup>PRO</sup>

## Accudraft Mix PRO™ Paint Mixing Room

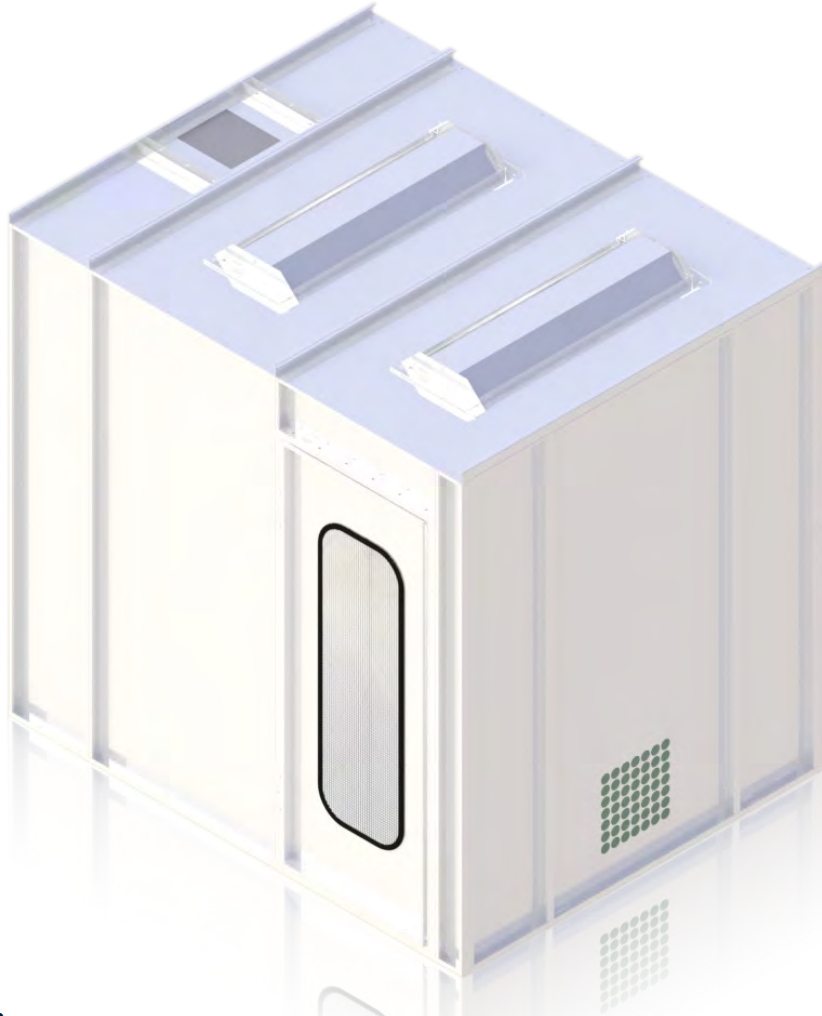

### STANDARD FEATURES

- 18 ga. Galvanized Steel Nut & Bolt Construction Panels
- 48" 4-Bulb Ceiling Lights
- 20" x 20" Ring Panel Filters. Ceiling Filter, Exhaust Filter Included
- 1 Personnel Door with Wire-Reinforced Glass
- 3 PHASE Motor/Fan Combination

# accudraft

I N D U S T R I A L

SAIMA of North America Inc.

Randolph, New Jersey 07869 | (800) 524-0340

info@accudraftpaintbooths.com | www.accudraftpaintbooths.com



# Mix<sup>PRO</sup>

# Mix<sup>PRO</sup>

## Accudraft Mix PRO™ Paint Mixing Room

### Drawing

Accudraft MixPRO paint mixing room. Blower and three phase-motor are included but not shown in the line drawing.

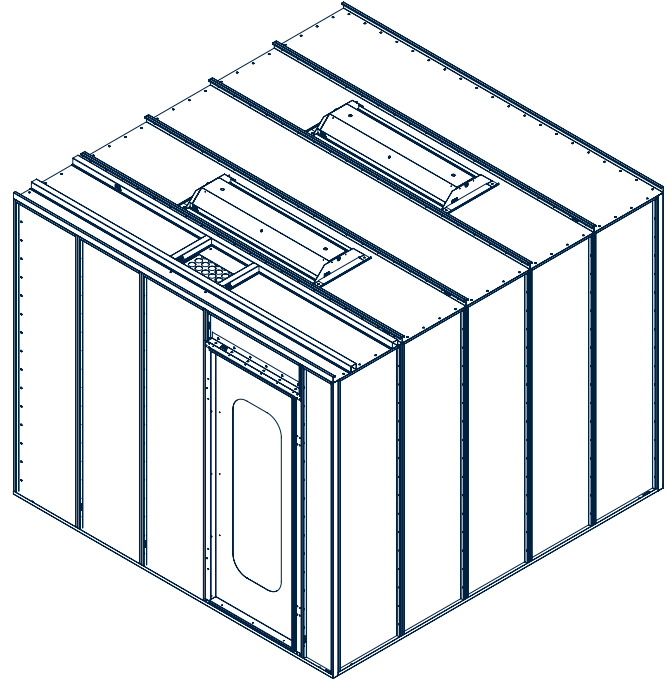

### Approximate Working Dimensions

- Starting at 6' x 8' x 9' High

### Construction

- Single Skin 18 Gauge
- Electrogalvanized Steel
- Computerized Pre-Punched Design
- Bolt-Together Construction
- Optional White on White Finish

### Man Door

- Approx Opening: 3' wide x 7' high
- Full Height Wire Reinforced Window
- Additional Access Door Optional

### Lighting

- 48" 4-tube Light Fixtures
- Daylight Corrected Lighting
- Outside Access Light Fixtures
- Optional Inside-Access Lights

### Intake Fan

- Positive Pressure System
- Varying CFM per Sqft
- Forward Curve Centrifugal Fan
- 3 Phase High Efficiency Motor

### Controls

- On/Off

### Optional Exhaust Unit

- Balanced Exhaust Unit
- Connecting Duct
- Ductwork Available but Not Included

### Certification

- ETL Listed

### Warranty

- 1 Year Limited Warranty

### Note

- SAIMA of North America reserves the right to modify or change any of the dimensions or features without notification.

